

# Product Catalog

Strength Machines and Core Equipment



**Gymleco**



"Our mission is to make not only Sweden, but the world, healthier, stronger and more sustainable."

**- Kari Jernvall**  
Founder and Product Designer

# Welcome

## Welcome to the Gymleco Family

Gymleco is a Swedish, family-owned company driven by a passion for health, strength, innovation, and sustainability. Today, we are one of Europe's leading designers and manufacturers of strength training equipment.

With customers worldwide, Gymleco has grown into a trusted gym machine brand known for innovative design and biomechanical precision. We offer a complete range of strength training and exercise equipment, and we are among the few manufacturers in the Nordics producing our equipment in-house.

We aim to be more than a supplier. We strive to be a total solution and a profitable, long-term investment for our customers.

Since 1994, Gymleco has focused on developing Swedish-made equipment that is functional, durable, and built for a long lifespan with minimal maintenance. We are truly passionate about fitness, and we invite you to join us in our ambition for a healthier world and a more sustainable future.

## Why choose Gymleco?

- Decades of experience
- Biomechanical precision
- Innovative, original design
- Low maintenance
- Commercial-grade quality use
- Space-efficient footprint
- Suitable for all users
- Ergonomically correct movement
- Affordable quality

# Contents

<b>Our History</b>	6
<b>Machine Features</b>	8
<b>Assistance and Warranty</b>	10
<b>Plate Loaded Machines</b> <i>10 series</i>	12
<b>Core Equipment</b> <i>100 series</i>	24
<b>Multi Gym &amp; Cable Stations</b> <i>200 series</i>	36
<b>Selectorized Machines</b> <i>300 series</i>	42
<b>Circuit Machines</b>	52
<b>Gymleco Distributors</b>	56



# Our History



1994

**Aims for a sustainable future**

Gymleco was founded in 1994 in a small kitchen in the south of Sweden, with a clear vision: to provide the fitness market with affordable, functional, and sustainable gym equipment. From the start, the ambition was to develop low-maintenance strength machines with exceptional functionality and quality.

Our equipment was designed to be “muscle-driven” throughout the entire movement, delivering effective resistance without placing unnecessary stress on the joints.

The goal has always been to create equipment that lasts for decades. Many of our customers still use Gymleco machines purchased in the 1990s, and they are still performing at a high level today.

From day one, we have focused on unique and innovative design, long lifespan, and compact footprints. We believe in our own construction and engineering – products built for a sustainable future.

2026

**Still going strong**

Our head office is located in Eskilstuna, Sweden, near Stockholm. Under one roof, you will find our production facilities, warehouse, and showroom. This enables full quality control – from order to shipment – and ensures that every product meets our high standards.

Our customer focus is reflected in clear communication and dependable service. Because we manufacture in-house, we can shorten delivery times and provide customized solutions beyond the standard product range.

Gymleco remains a family-owned company, working every day toward our vision of a healthier and more sustainable future. We stand behind every product we develop, creating Swedish-made equipment that combines correct movement, ease of use, and outstanding performance.

Everyone should be able to train correctly and safely. That is why Gymleco machines are designed to maximize training results, whether you are a beginner or a professional athlete. Most importantly, every movement is biomechanically correct.

# Machine Features

Gymleco machines are engineered for professional performance, combining superior biomechanics, durable construction and a clean Scandinavian design.

## A Professional Look That Sells

Gymleco machines combine function, form, and finish. The solid construction and clean Scandinavian design communicate quality instantly, elevating both the gym environment and the member experience.

## PowerBand™ Drive System

Gymleco machines use PowerBand™ instead of cables, eliminating stretching and adjustments. It delivers a smooth, consistent feel throughout the full range of motion and comes with a 10-year guarantee in our 300-series machines.

## Built for a Lifetime

All Gymleco machines are constructed using heavy-duty steel profiles and reinforced welding joints. This results in exceptional stability and durability, which is why we offer a lifetime warranty on steel frames and welds.

## Biomechanics at the Core

Every movement is engineered to follow the body's natural strength curve. Gymleco machines provide smooth, consistent resistance throughout the entire range of motion, maximizing training efficiency while reducing joint stress.

## Maintenance-Free Performance

Equipped with maintenance-free bearings and high-quality components, Gymleco machines ensure minimal friction, silent operation, and reduced service requirements – lowering total cost of ownership.

## Superior Ergonomics and Comfort

Seats, pads, and contact points are ergonomically designed to ensure optimal positioning. High-density upholstery delivers lasting comfort, even under heavy, continuous use.

## Smart, Stable Design

Thoughtful features such as integrated weight stacks, stable foot platforms, and non-slip grips create a safe and controlled training experience. Machines can also be floor-bolted for maximum stability in commercial environments.

## Customizable Design Options

Choose frame colors, upholstery, and details to match your gym's identity. Gymleco offers extensive customization without compromising durability or performance.



# Assistance

You can handle everything yourself – but you don't have to. Gymleco supports you throughout the entire process, from gym planning to delivery and installation. When selecting equipment, our specialists provide guidance and recommendations tailored to your facility, goals, and budget. Together, we review your needs and create the best possible solution.

## Ideas and planning

Our team supports you with gym planning, layout design, and floor plans for both small and large facilities. We help you find smart, sustainable solutions that optimize space, strengthen your business, and create the best possible training experience.

## Delivery

We offer fast delivery to gyms, companies, and private customers. Gymleco delivers worldwide. If there is a local distributor or sales office in your country, they will support you throughout the process.

## Assembly and Installation

In most cases, our machines are delivered fully assembled. Installation at your facility can be arranged through Gymleco staff or approved third-party partners. If you are located in a country with an official distributor, installation arrangements are handled directly between you and your local partner.

# Warranty

## Warranty – ISO 9001 Quality Assurance

Gymleco's warranty program ensures that your equipment remains reliable and fully functional over time. Our products are designed and manufactured for high performance combined with low-maintenance operation. To maintain consistent quality and continuous improvement, Gymleco follows the ISO 9001 quality management system.

Our warranty clearly defines coverage for key equipment components, and spare parts are always kept in stock for fast delivery.

- Lifetime warranty on all steel frames and welds (covers manufacturing and material defects).
- 10-year warranty on Powerband™ (300-series only), band stretching systems, bearings, band wheels, and seat adjustment systems (covers manufacturing and material defects).
- 1-year warranty on upholstery pads and Powerband™ (200-series).

## ISO 9001 Quality Management System

Gymleco operates according to the ISO 9001 quality management system to ensure control, continuous improvement, and reliable manufacturing processes. This structured approach improves efficiency and ensures the highest product quality for our customers.

The goals of ISO 9001 include: superior quality, accurate delivery, competitive pricing, fast production, and high service levels. Since all Gymleco products are produced in-house, we maintain full control over both quality and production standards.

We take pride in every product we manufacture, and we strive to provide the finest gym equipment on the market.



010 SERIES

## Plate Loaded Machines

Plate loaded machines are strength training machines where the resistance is loaded using weight plates. Gymleco's plate loaded equipment is engineered for high performance, low maintenance, and a space-efficient footprint to help you optimize your gym layout and fit more machines on the floor.

Each machine is designed with a carefully developed movement path to support correct biomechanics and a natural training feel. With minimal adjustments, the machines are easy to use for both beginners and experienced athletes.

Built with premium commercial-grade materials, Gymleco plate loaded machines are made to withstand heavy usage year after year, without frequent service needs or parts failure.

The levers are independently linked, allowing unilateral movement and improving coordination between the left and right side. This design supports faster development of muscle balance.





**Iso Lateral Seated Row**  
Art.nr: 010

Length: 150 cm  
Width: 71 cm  
Height: 120 cm

Weight: 68,5 kg



**Iso Lateral Pulldown**  
Art.nr: 011

Length: 156 cm  
Width: 104 cm  
Height: 199 cm

Weight: 136 kg



**Iso Lateral Low Row**  
Art.nr: 012

Length: 120 cm  
Width: 112 cm  
Height: 174 cm

Weight: 112 kg



**Seated Chest Press**  
Art.nr: 021

Length: 176 cm  
Width: 114 cm  
Height: 140 cm

Weight: 101 kg



**Iso Lateral Bench Press,  
Horizontal**  
Art.nr: 022

Length: 163 cm  
Width: 133 cm  
Height: 114 cm

Weight: 92,5 kg



**Incline Pec Fly**  
Art.nr: 023

Length: 160 cm  
Width: 165 cm  
Height: 90 cm

Weight: 100 kg



**Iso Lateral High Row**  
Art.nr: 013

Length: 160 cm  
Width: 110 cm  
Height: 198 cm

Weight: 152 kg



**D.Y. Row**  
Art.nr: 017

Length: 135 cm  
Width: 147 cm  
Height: 174 cm

Weight: 144 kg



**Lateral Incline Bench Press**  
Art.nr: 020

Length: 110 cm  
Width: 113 cm  
Height: 177 cm

Weight: 115 kg



**Decline Chest Press**  
Art.nr: 027

Length: 120-133 cm  
Width: 144 cm  
Height: 158 cm

Weight: 120 kg



**Standing Chest Press**  
Art.nr: 028

Length: 152 cm  
Width: 100 cm  
Height: 163 cm

Weight: 135 kg



**Incline Press / Chest Flyes**  
Art.nr: 029

Length: 100 cm  
Width: 127 cm  
Height: 170 cm

Weight: 120 kg



029 Incline Press / Chest Flies



**Shoulder Press**  
Art.nr: 030

Length: 130 cm  
Width: 114 cm  
Height: 149 cm

Weight: 111 kg



**Shoulder Rotation**  
Art.nr: 031

Length: 105 cm  
Width: 114 cm  
Height: 135 cm

Weight: 95,5 kg



**Upright Row**  
Art.nr: 032

Length: 120 cm  
Width: 140 cm  
Height: 94 cm

Weight: 79,2 kg



**Viking Press**  
Art.nr: 038

Length: 121 cm  
Width: 98 cm  
Height: 154 cm

Weight: 125 kg  
Start weight handles: 21 kg



**Leg Extension**  
Art.nr: 040

Length: 92 cm  
Width: 120 cm  
Height: 130 cm

Weight: 79 kg



**Seated Leg Curl**  
Art.nr: 041

Length: 125 cm  
Width: 100 cm  
Height: 110 cm

Weight: 95,5 kg



**Standing Leg Curl**  
Art.nr: 042

Length: 96 cm  
Width: 117 cm  
Height: 123 cm

Weight: 83,5 kg



**Leg Press**  
Art.nr: 043

Length: 226 cm  
Width: 120 cm  
Height: 138 cm

Weight: 130 kg



**V-Squat**  
Art.nr: 044

Length: 171 cm  
Width: 87 cm  
Height: 191 cm

Weight: 115 kg



**Biceps curl machine**  
Art.nr: 050

Length: 104 cm  
Width: 120 cm  
Height: 103 cm

Weight: 91 kg



**Iso Lateral Triceps**  
Art.nr: 051

Length: 124 cm  
Width: 102 cm  
Height: 136 cm

Weight: 96 kg



**Dip Press**  
Art.nr: 055

Length: 190 cm  
Width: 70 cm  
Height: 90 cm

Weight: 84 kg



**Pendulum Squat**  
Art.nr: 045

Length: 195 cm  
Width: 108 cm  
Height: 161 cm

Weight: 150 kg



**Donkey Raise**  
Art.nr: 046

Length: 120 cm  
Width: 60 cm  
Height: 150 cm

Weight: 65 kg



**Tibia Dorsi Flexion**  
Art.nr: 047

Length: 102 cm  
Width: 60 cm  
Height: 51 cm

Weight: 35,5 kg



**Gluteus, One Leg kick**  
Art.nr: 060

Length: 126 cm  
Width: 119 cm  
Height: 133 cm

Weight: 112,5 kg



**Reverse Hyper**  
Art.nr: 061

Length: 116 cm  
Width: 140 cm  
Height: 144 cm

Weight: 87,5 kg



**Standing Abductor**  
Art.nr: 062

Length: 136,5 cm  
Width: 54 cm  
Height: 141,5cm

Weight: 90 kg



**Reverse Hyper Pendulum**  
Art.nr: 063

Length: 137 cm  
Width: 133,5 cm  
Height: 111 cm

Weight: 90 kg



**Hip Thrust machine**  
Art.nr: 066

Length: 160 cm  
Width: 96 cm  
Height: 124 cm

Weight: 109 kg



**Belt Squat machine**  
Art.nr: 082

Length: 170 cm  
Width: 116 cm  
Height: 112 cm

Weight: 90 kg



**Deadlift / Squat**  
Art.nr: 083

Length: 140 cm  
Width: 129,5 cm  
Height: 82 cm

Weight: 96 kg  
Start weight: 23 kg



**Seated Abdominal**  
Art.nr: 070

Length: 83 cm  
Width: 114 cm  
Height: 168 cm

Weight: 72 kg



**Ab Roll up**  
Art.nr: 072

Length: 100 cm  
Width: 96 cm  
Height: 140 cm

Weight: 72,5 kg



062 Standing Abductor Plate Loaded



244 Hack Lift



**Leg Press 45°**  
Art.nr: 243

This leg machine has a tasteful design, stable construction and is space efficient. The large footplate and the ergonomically designed seat provides great freedom in the exercise. An additional central handle facilitates the access to the machine.

The trolley weighs 56kg (at a 45 degree inclination in the machine, 39.5 kg of that weight comes to the feet).

Length: 218 cm  
Width: 78 cm  
Height: 142 cm  
Weight: 161,5 kg



**Hack Lift**  
Art.nr: 244

This hacklift machine provides you a tasteful design and an open construction without compromising on function or stability. You both save space at the gym and have a great, safe machine for the users.

The trolley weighs 47,4kg (at a 45 degree inclination in the machine, 33.5 kg of that weight comes to the feet)

Length: 195 cm  
Width: 80 cm  
Height: 145 cm  
Weight: 137,5 kg



**Leg Press/Hack Lift**  
Art.nr: 245

This Leg Press / Hacklift is probably the only combination machine in the world where you can switch exercise with only one setting and no loose parts. This combined leg machine has a small footprint and smart design. For example the weight plates are loaded in the centre of the machine instead of the outside.

Length: 230 cm  
Width: 81 cm  
Height: 145 cm  
Weight: 180 kg

100 SERIES

## Core Gym Equipment

Gymleco's core equipment is manufactured to commercial standards and is an ideal choice for professional gyms that demand durable, long-lasting products.

The 100-series consists of user-friendly equipment suitable for a wide variety of gym environments. Here you will find benches, bench press stations, racks, and selected plate loaded machines. Every product is built for heavy use and has been tested and proven for over 30 years.

If you are also looking for gym accessories such as dumbbells, barbells, and weight plates, please refer to our accessories catalog.

  
Gymleco

  
BOOTY CORNER  
Powered by Gymleco





**Sissy Squat**  
Art.nr: 144

Length: 77 cm  
Width: 64 cm  
Height: 57 cm

Weight: 27,5 kg



**Seal Row Bench**  
Art.nr: 117

Length: 147 cm  
Width: 122,5 cm  
Height: 91 cm

Weight: 55 kg

*The barbell is not included.*



**Seal Row Bench  
Open Model**  
Art.nr: 118

Length: 112 cm  
Width: 125 cm  
Height: 90 cm

Weight: 50 kg



**Back Raise, Adjustable  
45-90 degrees**  
Art.nr: 162

Length: 102 cm  
Width: 60 cm  
Height: 117 cm

Weight: 41,5 kg



**Back Raise 45 degrees**  
Art.nr: 162F45

Length: 102 cm  
Width: 60 cm  
Height: 117 cm

Weight: 38 kg



**Back Raise 90 degrees**  
Art.nr: 162F90

Length: 102 cm  
Width: 60 cm  
Height: 104 cm

Weight: 36,5 kg



**T-bar Row**  
Art.nr: 115

Length: 206 cm  
Width: 86 cm  
Height: 47 cm

Weight: 59,5 kg



**Incline T-bar row**  
Art.nr: 116

Length: 195–212 cm  
Width: 92 cm  
Height: 109 cm

Weight: 69 kg



**Seated Calf Press**  
Art.nr: 145

Length: 140 cm  
Width: 60 cm  
Height: 85 cm

Weight: 54,5 kg



**Calf Raise Block**  
Art.nr: 146

Length: 51 cm  
Width: 30 cm  
Height: 12 cm

Weight: 6,5 kg



**Knee standing Back Raise**  
Art.nr: 163

Length: 105 cm  
Width: 59 cm  
Height: 79 cm

Weight: 38 kg



**Glute Ham Raise**  
Art.nr: 141

Length: 110 cm  
Width: 60 cm  
Height: 90 cm

Weight: 51 kg



**Bench Press and Squat Rack**  
Art.nr: 142

Length: 60  
Width: 45-125 cm  
Height: 79,5 - 162,5 cm

Weight: 31 kg



**Squat Rack**  
Art.nr: 148

Length: 162 cm  
Width: 100 cm  
Height: 186 cm

Weight: 65 kg



**Power Rack**  
Art.nr: 149

Length: 90 cm  
Width: 122 cm  
Height: 205 cm

Weight: 76,5 kg



**Curl Bar Rack**  
Art.nr: 150

Length: 70 cm  
Width: 95 cm  
Height: 86,5 cm

Weight: 22 kg



**Seated Scott Curl Bench**  
Art.nr: 151

Length: 101 cm  
Width: 70 cm  
Height: 95 cm

Weight: 35,5 kg



**Standing Scott Curl Bench**  
Art.nr: 152

Length: 63 cm  
Width: 53 cm  
Height: 92 cm

Weight: 26 kg



**Lifting Rack for Decline Bench**  
Art.nr: 154

Length: 125 cm  
Width: 170 cm  
Height: 110 cm

Weight: 52,5 kg



**Dip Press stand**  
Art.nr: 155

Length: 80 cm  
Width: 80 cm  
Height: 140 cm

Weight: 37 kg



**Hip Thrust bench**  
Art.nr: 166

Length: 150 cm  
Width: 73 cm  
Height: 50 cm

Weight: 43,5 kg



**Glute Bridge**  
Art.nr: 167

Length: 135 cm  
Width: 105 cm  
Height: 47 cm

Weight: 50 kg



**Roman Chair**  
Art.nr: 170

Length: 102 cm  
Width: 58 cm  
Height: 57 cm

Weight: 21 kg



**Leglift with Dip Bar**  
Art.nr: 173

Length: 70 cm  
Width: 91 cm  
Height: 143 cm

Weight: 68 kg



**Leglift with Chins and Dips**  
Art.nr: 179

Length: 70 cm  
Width: 91 cm  
Height: 227 cm

Weight: 78 kg



179 Leglift with Chins and Dips



**Bench Press Stand with Adjustable Bar Holder**  
Art.nr: 122R

Length: 125 cm  
Width: 124 cm  
Height: 104 cm

Weight: 46 kg



**Bench Press with Safety Bar Support**  
Art.nr: 122RS

Length: 125 cm  
Width: 124 cm  
Height: 104 cm

Weight: 46 kg



**Bench Press with Fixed Bar Holder**  
Art.nr: 122F

Length: 123 cm  
Width: 123 cm  
Height: 124 cm

Weight: 53 kg



**Incline Bench Press**  
Art.nr: 120

Length: 125 cm  
Width: 150 cm  
Height: 124 cm

Weight: 61 kg



**Abdominal Bench Plus**  
Art.nr: 171

Length: 102 cm  
Width: 58 cm  
Height: 105 cm

Weight: 22 kg



**Brutal Bench**  
Art.nr: 174

Length: 75 cm  
Width: 50 cm  
Height: 160 cm

Weight: 24 kg

Add Dip Rack for Brutal Bench

Art.nr: 174-1

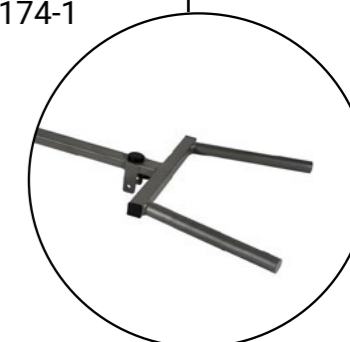

**Chin Rack for Cable Cross**  
Art.nr: 110K

Length: 140 cm  
Width: 18 cm

Weight: 6,5 kg



**Wallmounted Pull-up Rack**  
Art.nr: 110V

Length: 145 cm  
Width: 61,5 cm  
Height: 42 cm

Weight: 9,5 kg



**Standing Chins Rack**  
Art.nr: 111

Length: 123 cm  
Width: 145 cm  
Height: 237,5 cm

Weight: 73,5 kg



**Fixed Bench 70°**  
Art.nr: 153

Length: 76 cm  
Width: 40 cm  
Height: 90 cm

Weight: 19 kg



**Adjustable Gym Bench**  
Art.nr: 190

Length: 125 cm  
Width: 45 cm  
Height: 43,5 cm

Weight: 25,5, kg



**Fixed Flat Bench**  
Art.nr: 191

Length: 123 cm  
Width: 45 cm  
Height: 38 cm

Weight: 24,5 kg



**Adjustable Decline Bench Curved**  
Art.nr: 193S

Length: 133 cm  
Width: 45 cm  
Height: 42 - 115 cm

Weight: 33 kg



**Adjustable Dumbbell Exercise Bench**  
Art.nr: 193V

Length: 130 cm  
Width: 53 cm  
Height: 27-115 cm

Weight: 35 kg



*Split backrest  
maximizes exercises  
such as dumbbell flies*



**Adjustable Flat Bench**  
Art.nr: 192

Length: 122 cm  
Width: 35,5 cm  
Height: 39,5-55 cm

Weight: 16 kg



**Fixed Dumbbell Exercise Bench**  
Art.nr: 191V

Length: 110,7 cm  
Width: 52,4 cm  
Height: 43 cm

Weight: 35 kg



**Adjustable Decline Bench**  
Art.nr: 193

Length: 133 cm  
Width: 45 cm  
Height: 42 - 115 cm

Weight: 31,5 kg



**Fixed Decline Bench**  
Art.nr: 194

Length: 148 cm  
Width: 60 cm  
Height: 60 cm

Weight: 27,5 kg



**Adjustable Decline Bench**  
Art.nr: 194R

Length: 148 cm  
Width: 60 cm  
Height: 60 cm

Weight: 27,5 kg

200 SERIES

## Cable Machines and Multi Gyms

The 200-series includes Gymleco's cable machines and multigyms, engineered for optimal performance and compact footprints. These machines are designed to deliver a smooth training experience with low friction and consistent resistance, resulting in better feel and improved training quality.

A key feature of Gymleco's cable machine design is the use of Powerband™ instead of traditional wire cables. Unlike wire systems, Powerband™ does not require adjustment, as it does not stretch in the same way over time. It also provides a smoother movement compared to conventional cable machines.

If needed, machines can be ordered with larger weight stacks to match user requirements.





**Seated Row**  
Art.nr: 210

Length: 235 cm  
Width: 67 cm  
Height: 215 cm

Weight: 173,5 kg  
Weight Stack: 100 kg



**Lateral Pulldown**  
Art.nr: 211

Length: 124 cm  
Width: 52 cm  
Height: 226 cm

Weight: 168,5 kg  
Weight Stack: 100 kg



**Lateral Pulldown Rehab**  
Art.nr: 211R

Length: 124 cm  
Width: 52 cm  
Height: 226 cm

Weight: 168,5 kg  
Weight Stack: 100 kg

*Pulldown position*

*Row position*



**Lateral Pulldown/Seated Row**  
Art.nr: 214

Length: 112 cm      Weight: 168,5kg  
Width: 141 - 212 cm      Weight Stack: 100 kg  
Height: 223 cm



**Four Station Multi Gym**  
Art.nr: 215

Length: 323 cm      Cable Cross: 80 kg  
Width: 53 cm      Row: 120 kg  
Height: 235,5 cm      Pulldown: 120 kg  
Weight N.W: 605 kg      Triceps: 60 kg



226 Dual Adjustable Pulley



**Multi gym /4 Station With Cable Cross**  
Art.nr: 215K

Length: 410 cm      Cable Cross: 80 kg x 2  
Width: 323 cm      Row: 120 kg  
Height: 235,5 cm      Pulldown: 120 kg  
Weight N.W: 762 kg      Triceps: 60 kg



**Multigym /8 Station With Cable Cross**  
Art.nr: 215DK

Length: 490 cm      Cable Cross: 80 kg x2  
Width: 323 cm      Row: 120 kg x2  
Height: 235,5 cm      Pulldown: 120 kg x2  
Weight N.W: 1347 kg      Triceps: 60 kg x2



**Triceps Pushdown**  
Art.nr: 251

Length: 110 cm  
Width: 70 cm  
Height: 223 cm

Weight: 126,5 kg  
Weight Stack: 60 kg



*Adjustable cushion  
for biceps and  
triceps training.*

**Biceps Curl /Triceps Extension**  
Art.nr: 255

Length: 192 cm  
Width: 60 cm  
Height: 180 cm

Weight: 145 kg  
Weight Stack: 60 kg



**Cable Crossover Multigym**  
Art.nr: 225

Length: 308 cm  
Width: 58 cm  
Height: 225 cm

Weight: 298 kg  
Weight Stack: 80 kg x 2



**Half of a Cable Cross**  
Art.nr: 225B

Length: 48 cm  
Width: 58 cm  
Height: 225 cm

Weight: 142 kg  
Weight Stack: 80 kg



**Dual Adjustable Pulley**  
Art.nr: 226

Length: 151 cm  
Width: 77 cm  
Height: 228 cm

Weight: 279 kg  
Weight Stack: 80 kg x 2



**Smith Machine**  
Art.nr: 280

Length: 195 cm  
Width: 90 cm  
Height: 207 cm

Weight: 113 kg

Bar weight only 16,5kg



**Smith Machine  
with counterweight**  
Art.nr: 281

Length: 207 cm  
Width: 90 cm  
Height: 208 cm

Weight: 115 kg



**Multi Smith Machine**  
Art.nr: 285

Length: 207 cm  
Width: 149 cm  
Height: 220 cm

Weight: 145 kg

300 SERIES

## SelectORIZED Machines

The 300-series consists of premium selectorized machines with integrated weight stacks. These machines are designed for facilities that demand the highest level of performance, durability and design quality.

At Gymleco, function always comes first. The 300-series features unique details such as Powerband™, which never requires adjustment, ensuring smooth and consistent performance over time. The weight stacks also feature a distinctive design that adds a premium and eye-catching look to any gym.

Constructed with commercial-grade materials, these machines are built to withstand years of heavy strength training. The compact footprint and timeless design make them ideal for modern fitness facilities. The movement patterns are simple, ergonomic and biomechanically correct, making them suitable for all user levels.

Some 300-series machines include an “R” after the article number, indicating an adjustable start angle.

If desired, machines can be ordered with larger weight stacks customized to user needs.





**Seated Row**  
Art.nr: 310

Length: 151 cm  
Width: 63 cm  
Height: 165 cm

Weight: 227 kg  
Weight Stack: 100 kg



**Iso Lateral Pulldown**  
Art.nr: 311

Length: 126 cm  
Width: 95 cm  
Height: 186 cm

Weight: 211 kg  
Weight Stack: 100 kg



**Iso Lateral Low Row**  
Art.nr: 312

Length: 121 cm  
Width: 81 cm  
Height: 166 cm

Weight: 206 kg  
Weight Stack: 100 kg



**Chins /Dips**  
Art.nr: 314

Length: 126 cm  
Width: 120 cm  
Height: 200 cm

Weight: 236 kg  
Weight Stack: 100 kg



**Incline Chest Press**  
Art.nr: 320

Length: 156 cm  
Width: 122 cm  
Height: 173 cm

Weight: 218 kg  
Weight Stack: 100 kg



**Seated Chest Press**  
Art.nr: 321

Length: 139 cm  
Width: 137 cm  
Height: 149 cm

Weight: 224 kg  
Weight Stack: 100 kg



311 Iso Lateral Pulldown



**Seated Pec Deck**  
Art.nr: 323

Length: 146 cm  
Width: 171 cm  
Height: 150 cm

Weight: 198,5 kg  
Weight Stack: 100 kg



**Pullover**  
Art.nr: 324

Length: 143 cm  
Width: 89 cm  
Height: 172 cm

Weight: 190 kg  
Weight Stack: 100 kg



**Standing Pec Fly**  
Art.nr: 326

Length: 116 cm  
Width: 148 cm (widest point)  
Height: 178 cm

Weight: 200 kg  
Weight Stack: 120 kg



**Standing Side Lateral**  
Art.nr: 334

Length: 116 cm  
Width: 82 cm  
Height: 160 cm

Weight: 190 kg  
Weight Stack: 80 kg



**Rear Deltoid/Pec Deck**  
Art.nr: 335

Length: 147 cm  
Width: 70 - 174 cm  
Height: 149 cm

Weight: 224 kg  
Weight Stack: 100 kg



**Shoulder Front Press**  
Art.nr: 336

Length: 120 cm  
Width: 110 cm  
Height: 165 cm

Weight: 240 kg  
Weight Stack: 100 kg



**Shoulder Press**  
Art.nr: 330

Length: 155 cm  
Width: 125 cm  
Height: 165 cm

Weight: 234 kg  
Weight Stack: 100 kg



**Shoulder Rotation**  
Art.nr: 331

Length: 87 cm  
Width: 75 cm  
Height: 135 cm

Weight: 168 kg  
Weight Stack: 80 kg



**Rear Deltoid Shoulder**  
Art.nr: 333

Length: 147 cm  
Width: 70 - 174 cm  
Height: 149 cm

Weight: 224 kg  
Weight Stack: 60 kg



**Leg Extension**  
Art.nr: 340

Length: 95 cm  
Width: 99 cm  
Height: 162 cm

Weight: 202 kg  
Weight Stack: 100 kg



**Leg Extension Adjustable**  
Art.nr: 340R

Length: 95 cm  
Width: 99 cm  
Height: 162 cm

Weight: 213 kg  
Weight Stack: 100 kg



**Seated Leg Curl**  
Art.nr: 341

Length: 135 cm  
Width: 95 cm  
Height: 149 cm

Weight: 163,5 kg  
Weight Stack: 80 kg



**Lying Leg Curl**  
Art.nr: 342

Length: 170 cm  
Width: 97 cm  
Height: 149 cm

Weight: 173,5 kg  
Weight Stack: 80 kg



**Lying Leg Curl, Adjustable**  
Art.nr: 342R

Length: 170 cm  
Width: 97 cm  
Height: 149 cm

Weight: 182,5 kg  
Weight Stack: 80 kg



**Seated Leg Press**  
Art.nr: 343

Length: 221 cm  
Width: 116 cm  
Height: 162 cm

Weight: 316 kg  
Weight Stack: 150 kg



**Seated Calf Press 45°**  
Art.nr: 348

Length: 140 cm  
Width: 100 cm  
Height: 142 cm

Weight: 255 kg  
Weight Stack: 150 kg



**Leg Extension / Leg Curl**  
Art.nr: 349

Length: 115 cm  
Width: 99 cm  
Height: 163 cm

Weight: 224 kg  
Weight Stack: 100 kg



**Biceps Curl machine**  
Art.nr: 350

Length: 100 cm  
Width: 95 cm  
Height: 153 cm

Weight: 153 kg  
Weight Stack: 60 kg



**Horizontal Lying Leg Press**  
Art.nr: 344 **NEW!**

Length: 221 cm  
Width: 116 cm  
Height: 162 cm

Weight: 316 kg  
Weight Stack: 150 kg



**Seated Calf Press**  
Art.nr: 345

Length: 120 cm  
Width: 60 cm  
Height: 140 cm

Weight: 203 kg  
Weight Stack: 120 kg



**Standing Calf Press**  
Art.nr: 347

Length: 130 cm  
Width: 60 cm  
Height: 180 cm

Weight: 247 kg  
Weight Stack: 150 kg



**Triceps Extension**  
Art.nr: 351

Length: 136 cm  
Width: 67,5 cm  
Height: 134 cm

Weight: 182 kg  
Weight Stack: 100 kg



**Dips Press / Shoulder Pull**  
Art.nr: 354

Length: 174 cm  
Width: 85 cm  
Height: 136 cm

Weight: 235 kg  
Weight Stack: 100 kg



**Biceps / Triceps**  
Art.nr: 355

Length: 129 cm  
Width: 84 cm  
Height: 149 cm

Weight: 170 kg  
Weight Stack: 60 kg



**Forearm machine**  
Art.nr: 356

Length: 61 cm  
Width: 75 cm  
Height: 136 cm

Weight: 147,5 kg  
Weight Stack: 80 kg



**Forearm Curl**  
Art.nr: 357

Length: 93 cm  
Width: 78 cm  
Height: 103 cm

Weight: 152 kg  
Weight Stack: 80 kg



**Gluteus, One Leg kick**  
Art.nr: 360

Length: 86 cm  
Width: 75 cm  
Height: 136 cm

Weight: 187 kg  
Weight Stack: 100 kg



**Lumbar/Abdominal  
(with armrest)**  
Art.nr: 365B

Length: 100 cm  
Width: 90 cm  
Height: 160 cm

Weight: 230 kg  
Weight Stack: 100 kg



**Multihip**  
Art.nr: 369

Length: 115 cm  
Width: 110 cm  
Height: 160 cm

Weight: 177 kg  
Weight Stack: 60 kg



**Seated Abs machine**  
Art.nr: 370

Length: 170 cm  
Width: 101 cm  
Height: 104 cm

Weight: 176 kg  
Weight Stack: 60 kg



**Standing Abductor**  
Art.nr: 362

Length: 110 cm  
Width: 65 cm  
Height: 142 cm

Weight: 210 kg  
Weight Stack: 100 kg



**Adductor/Abductor**  
Art.nr: 364

Length: 130 cm  
Width: 86 cm  
Height: 137 cm

Weight: 192 kg  
Weight Stack: 80 kg



**Lumbar/Abdominal**  
Art.nr: 365A

Length: 100 cm  
Width: 90 cm  
Height: 160 cm

Weight: 225 kg  
Weight Stack: 100 kg



**Torso Rotation**  
Art.nr: 375

Length: 120 cm  
Width: 75 cm  
Height: 139 cm

Weight: 155 kg  
Weight Stack: 60 kg



**Kneestanding Abdominal**  
Art.nr: 376

Length: 95 cm  
Width: 65 cm  
Height: 125 cm

Weight: 146,5 kg  
Weight Stack: 60 kg

900 SERIES

## Circuit Machines

Gymleco's 900-series offers commercial circuit training machines designed for fitness centers, corporate gyms, and rehabilitation facilities. The series consists of ten double-acting hydraulic machines covering all major muscle groups, enabling full-body training that is both fast and efficient.

Whether you want to add a few circuit machines to your facility or build an entire circuit zone, the Gymleco 900-series is a reliable and effective choice.

The machines use hydraulic resistance and are extremely easy to understand and use for all training levels and ages. Most machines offer two exercises in one, making the series highly space-efficient and versatile. You will find at least one machine per muscle group, making it ideal for full-body circuit programming.

Circuit training has been popular in gyms for decades. Many facilities place the machines in a circular layout and use them for group circuit classes. This setup provides a complete full-body workout in a single session, and the machines are also well suited for rehabilitation training.





**Pulldown / Shoulder Press**  
Art.nr: 911

Length: 113 cm  
Width: 69 cm  
Height: 115 cm  
Weight: 45 kg



**Chest Press / Back**  
Art.nr: 921

Length: 101 cm  
Width: 76 cm  
Height: 124 cm  
Weight: 43 kg



**Pec Dec/ Rear Deltoid  
Shoulder**  
Art.nr: 935

Length: 100 cm  
Width: 125 cm  
Height: 112 cm  
Weight: 50 kg



**Biceps / Triceps**  
Art.nr: 955

Length: 100 cm  
Width: 76 cm  
Height: 125 cm  
Weight: 45 kg



**Adductor / Abductor**  
Art.nr: 964

Length: 133 cm  
Width: 74 cm  
Height: 112 cm  
Weight: 56 kg



**Abs / Lower Back**  
Art.nr: 965

Length: 100 cm  
Width: 83 cm  
Height: 135 cm  
Weight: 46 kg



**Squat / Hacklift**  
Art.nr: 944

Length: 173 cm  
Width: 86 cm  
Height: 107 cm  
Weight: 67 kg



**Leg Extension / Legcurl**  
Art.nr: 949

Length: 105 cm  
Width: 77 cm  
Height: 117 cm  
Weight: 63 kg



**Shoulder Lift / Dips**  
Art.nr: 954

Length: 100 cm  
Width: 69 cm  
Height: 112 cm  
Weight: 45 kg



**Waist Rotator**  
Art.nr: 975

Length: 89 cm  
Width: 66 cm  
Height: 104 cm  
Weight: 38 kg

# Gymleco Distributors



## Find your local distributor

Scan the QR code to find your local distributor.  
If your country is not listed, our Head Office will be happy to assist you directly.

We sell and ship worldwide.

**Scan for distributors**

[gymleco.com/pages/distributors](https://gymleco.com/pages/distributors)

## The Head Office | Sweden

Fitness Trade Europe AB

 [gymleco.com](https://gymleco.com)

 +46 8-500 052 08

 [contact@gymleco.se](mailto:contact@gymleco.se)

## Follow us on social media

Instagram, TikTok, Facebook, LinkedIn, YouTube:  
[@gymleco](#)

[www.gymleco.com](http://www.gymleco.com)  
@gymleco